

To Honor American Military Aviation Through Flight, Exhibition and Remembrance

North American PBJ-1J N5865V Extraction





Overview



- 5 points of access

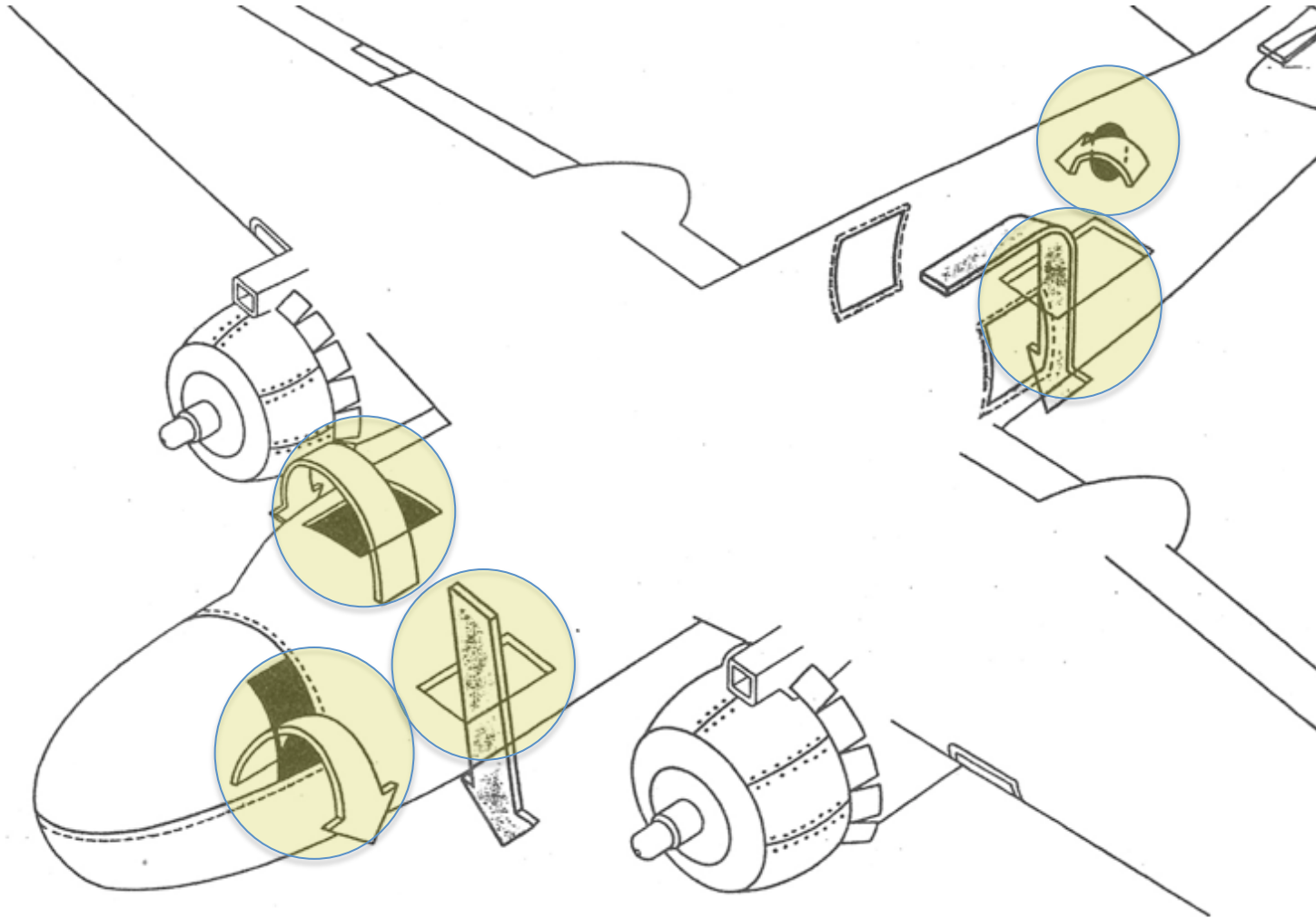

To Honor American Military Aviation Through Flight, Exhibition and Remembrance



Lower Access Doors

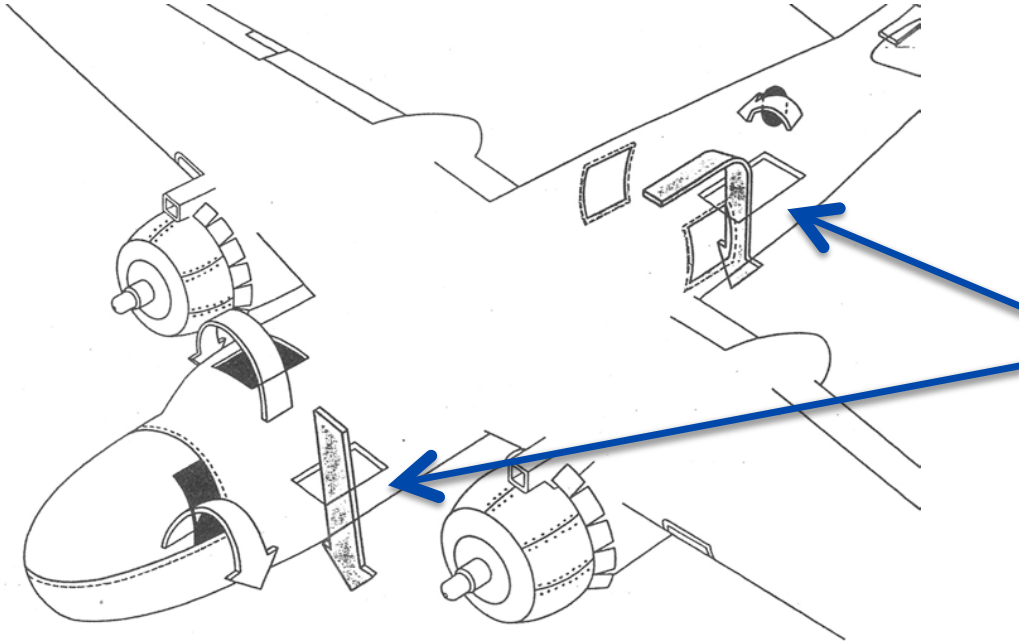

To Honor American Military Aviation Through Flight, Exhibition and Remembrance



Lower Access Doors



- 2 lower access doors used for all normal ops
- ***Caution - ladders fall open with gravity



To Honor American Military Aviation Through Flight, Exhibition and Remembrance



Emergency Access

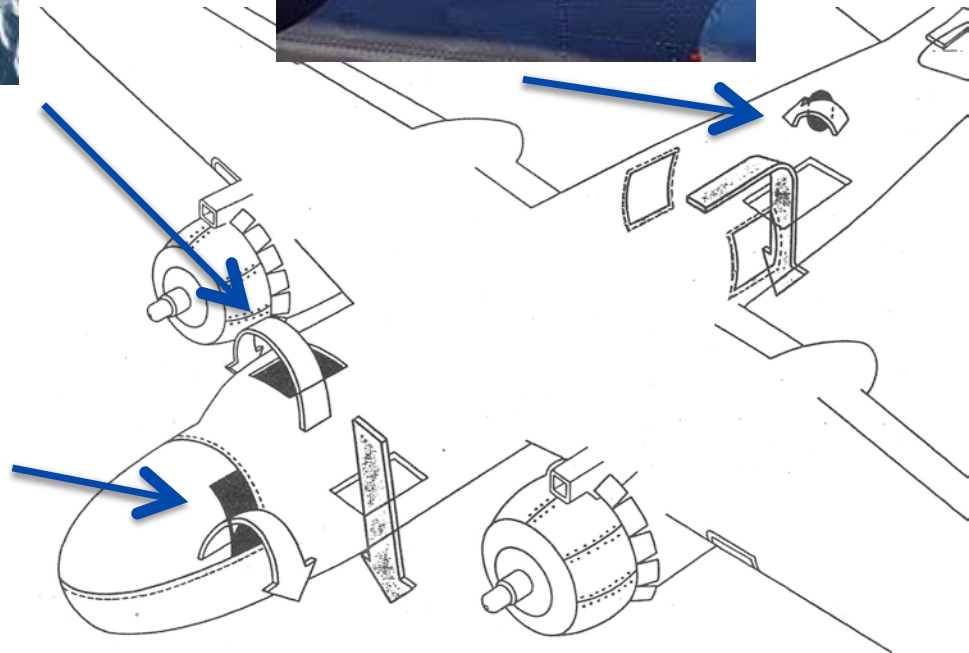

To Honor American Military Aviation Through Flight, Exhibition and Remembrance



Emergency Access



- Open by pushing in red door/handle
- All emergency access doors open into aircraft

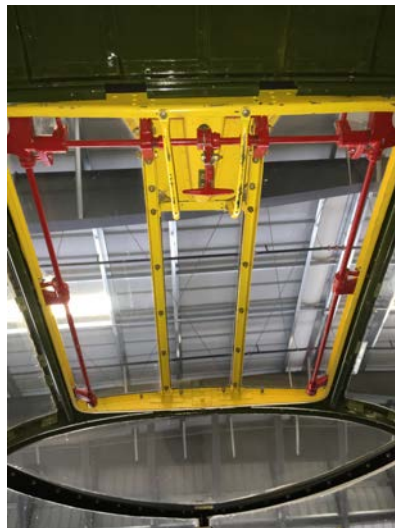

To Honor American Military Aviation Through Flight, Exhibition and Remembrance



Cockpit Switches

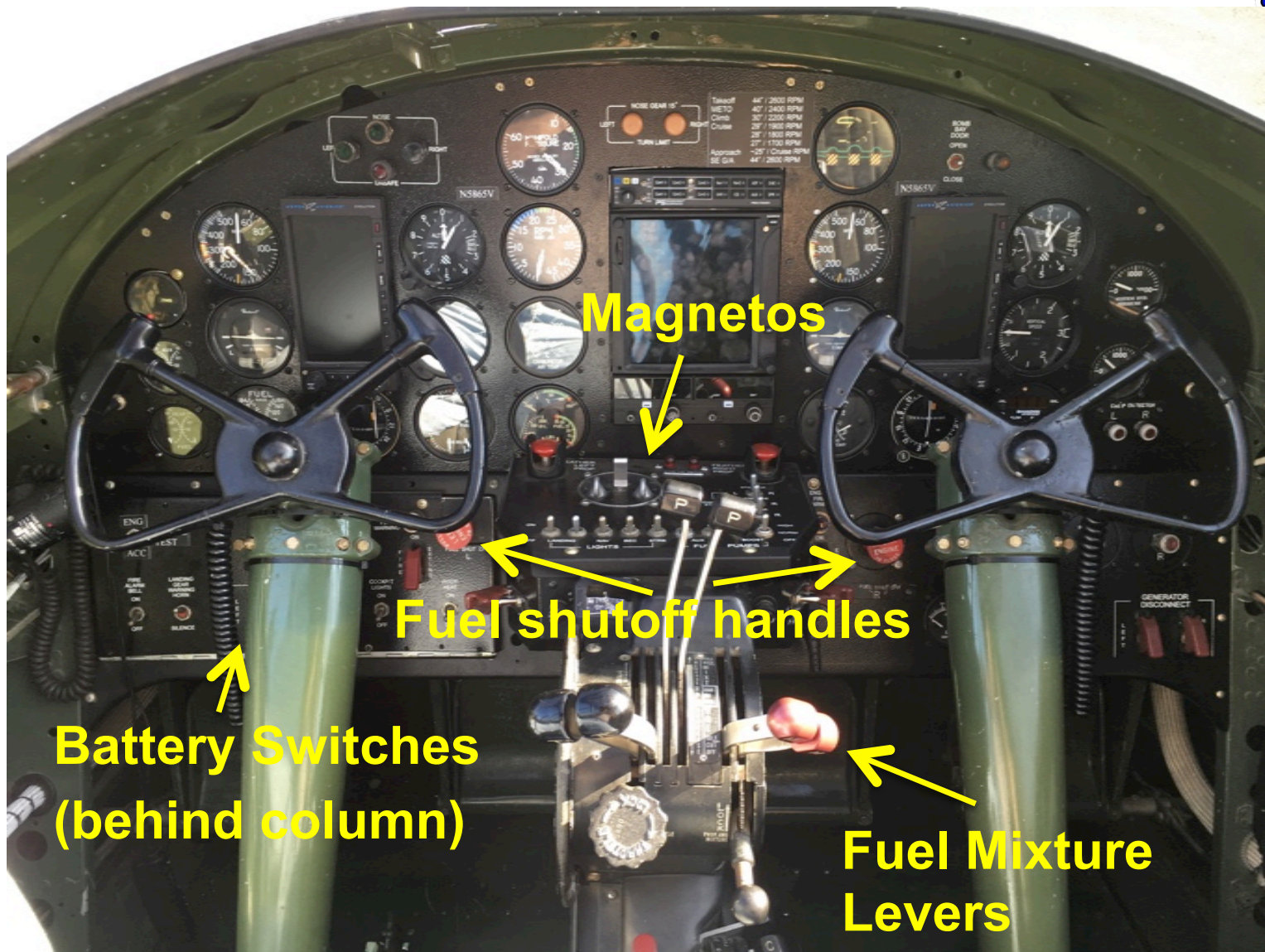

To Honor American Military Aviation Through Flight, Exhibition and Remembrance



Important Info



- **North American PBJ-1J (B-25J)**
 - N5865V
 - 670 gallons of fuel (max load)
 - 3 crew (2 pilots, crew chief)
- **Emergency contact**
 - CAF SoCal operations (805) 428-6806



To Honor American Military Aviation Through Flight, Exhibition and Remembrance